

ROTARY BALL SPLINE

The rotary ball spline can be used for both rotational motion and linear motion. It can be used in scalar robots, the vertical shaft of assembly equipment, and tool changers and loaders.

STRUCTURE AND ADVANTAGES

The rotary ball spline consists of a spline shaft and a nut. The nut has a spline portion and a rotating portion.

Reduced Number of Parts:

Because of the single-body construction consisting of the rotating portion which is equipped with cross roller elements and the spline portion, the number of parts is reduced and the cumulative installation error is reduced.

Compact and Light:

the cross roller is directly attached to the ball spline's external cylinder, resulting in a compact and light design.

Substantial Reduction in Installation Cost:

The use of cross roller elements keeps the housing thickness to a minimum, making the ball spline light and easy to install.

High Rigidity:

The cross roller elements and 4-row ball spline structure provides high rigidity in spite of the compact design.

High Accuracy:

The cross roller elements ensure accurate positioning in the rotational direction.

New

Figure B-20 Structure of Rotary Ball Spline

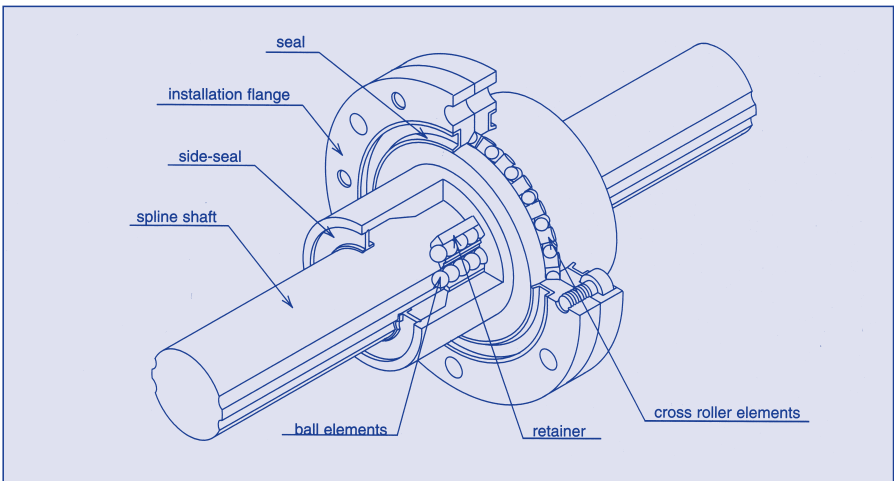

M

ROTARY BALL SPLINE

New

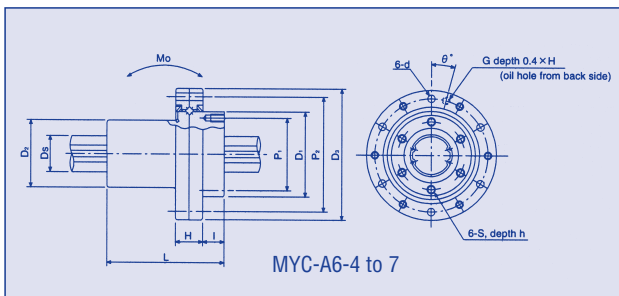
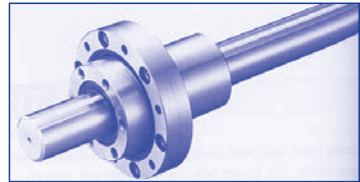
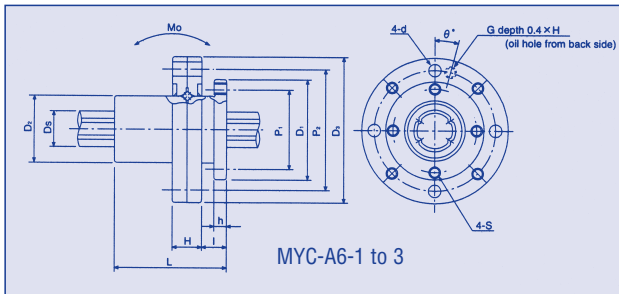

Material: Chrome Steel
Add SS to P/N for Stainless Steel

* Must specify length of spline shaft

Part Number	ball spline major dimensions										major dimensions of support bearing						
	D	tolerance	D ₂	L	P ₁	S	h	l	H	D _a	P ₂	d	G	θ°			
	mm	μm	mm	mm	mm	mm	mm	mm	mm	mm	mm	mm	mm	mm			
MYC-A6-1	20	0	13	25	0	16	M2	2.5	5	6.5	30	0/-21	24	2.4	Ø2	20°	
MYC-A6-2	22	-21	15	25		18	M2.5	3	6	6.5	33	0	27	2.9			
MYC-A6-3	27		19	33		22	M3	4	8	7	40	-25	33	3.4			
MYC-A6-4	29		24	36	-0.2	24	M3	5	8	9	50	0	42	3.4	Ø3	15°	
MYC-A6-5	36	0	31	50		30	M4	6	10	11	60		0	50			4.5
MYC-A6-6	40	-25	34	60		34	M4	7	12	13	66		-30	56			4.5
MYC-A6-7	50		40	70	0/-0.3	42	M5	8	13	16	78		68	4.5	M6 X .75	15°	

part number	spline shaft		ball spline				support bearing		allowable static moment Mo N • M	second cross-sectional moment of inertia mm ⁴	cross-sectional coefficient mm ³	mass		*maximum rotational speed rpm
	Ds	tolerance	basic torque rating		basic load rating		dynamic	static				nut	spline shaft	
	mm	μm	C _r N • M	C _{st} N • M	C _d kN	C _{st} kN	C _d kN	C _{st} kN				kg	kg/m	
MYC-A6-1	6	0/-12	1.5	2.4	1.22	2.28	0.6	0.5	5.1	59	19.7	0.04	0.21	3500
MYC-A6-2	8	0	2.1	3.7	1.45	2.87	1.2	1.14	7.4	190	47.6	0.05	0.38	3500
MYC-A6-3	10	-15	4.4	8.2	2.73	5.07	2.4	2.45	18.0	461	92.2	0.09	0.60	3000
MYC-A6-4	13	0	21	39.2	2.67	4.89	3.0	3.70	13.7	1380	213	0.17	1.0	1800
MYC-A6-5	16	-18	60	110	6.12	11.2	5.6	6.70	46	2980	373	0.33	1.5	1500
MYC-A6-6	18.2	0	83	133	7.84	11.3	5.90	7.35	63	5050	554	0.45	2.0	1200
MYC-A6-7	23	-21	162	239	12.3	16.1	9.11	11.5	104	12700	1110	0.75	3.1	1000

* Maximum rotational speed for grease lubrication.
Contact Nordex for further information when higher speeds or oil lubrication is required.

1kN ≅ 102kgf 1N . M ≅ 0.102kgf.m

NORDEX

(800) 243-0986 70M
In CT (203) 775-4877

M

ROTARY BALL SPLINE

Material: Chrome Steel
Add SS to P/N for Stainless Steel

New

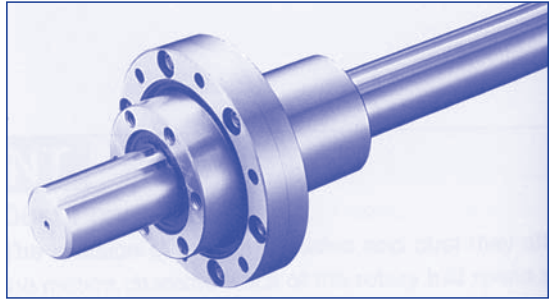

Part Number	ball spline major dimensions							major dimensions of support bearing							
	D ₁		D ₂		L		P ₁	N ₁ -S	h	ℓ	H	D ₃		P ₂	N ₂ -D
	mm	tolerance μm	mm	mm	mm	tolerance mm	mm		mm	mm	mm	mm	tolerance μm	mm	mm
MYC-A7-1	40	0	34	60	0/-0.2	34	6-M4	7	12	13	66	0	56	6-4.5	
MYC-A7-2	50	-25	40	70		42	6-M5	8	13	16	78	-30	68		
MYC-A7-3	61	0	47	80	0	52	6-M6	10	17	17	100	0	86	6-6.6	
MYC-A7-4	76	-30	62	100	-0.3	64			23	20	120	-35	104		
MYC-A7-5	88	0	75	112		77	6-M8	13	24	22	130	0	114	6-9	
MYC-A7-6	102	-35	90	127		90			25	25	150	-40	132		

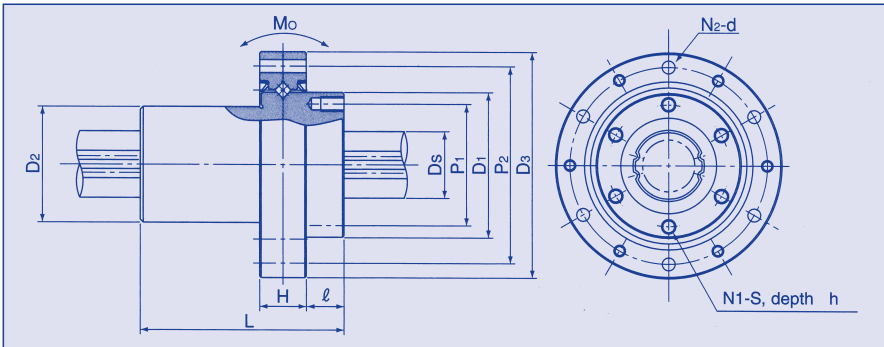

Specify length of Spline Shaft

Part Number	spline shaft		ball spline				support bearing		allowable static moment Mo N • M	second cross-sectional moment of inertia mm ⁴	cross-sectional coefficient mm ³	mass		*maximum rotational speed rpm
	mm	tolerance μm	basic torque rating		basic load rating		dynamic C _R kN	static C _{0R} kN				nut kg	spline shaft kg/m	
			C _T N • M	C _{0T} N • M	C kN	C ₀ kN								
MYC-A7-1	18.2		83	133	7.84	11.3	5.90	7.35	63	5.05 X 10 ⁴	5.54 X 10 ²	0.45	2.0	1,200
MYC-A7-2	23	0	162	239	12.3	16.1	9.11	11.5	104	1.27 X 10 ⁵	1.11 X 10 ³	0.75	3.1	1,000
MYC-A7-3	28	-21	289	412	18.6	23.2	13.2	18.0	181	2.75 X 10 ⁵	1.96 X 10 ³	1.25	4.8	800
MYC-A7-4	37.4	0	637	882	30.8	37.5	22.8	32.3	358	8.73 X 10 ⁵	4.67 X 10 ³	2.3	8.6	600
MYC-A7-5	47	-25	1,390	3,180	46.1	74.2	27.2	42.1	696	2.16 X 10 ⁶	9.21 X 10 ³	3.1	13.1	570
MYC-A7-6	56.5	0/-30	2,100	4,800	58.0	127.4	30.0	48.2	1,300	4.51 X 10 ⁶	1.60 X 10 ⁴	4.7	19	500

* Maximum rotational speed for grease lubrication.

1kN ≅ 102kgf 1N • M ≅ 0.102kgf.m

Contact Nordex for further information when higher speeds or oil lubrication is required.

71M (800) 243-0986
In CT (203) 775-4877

NORDEX